

Descriptif technique

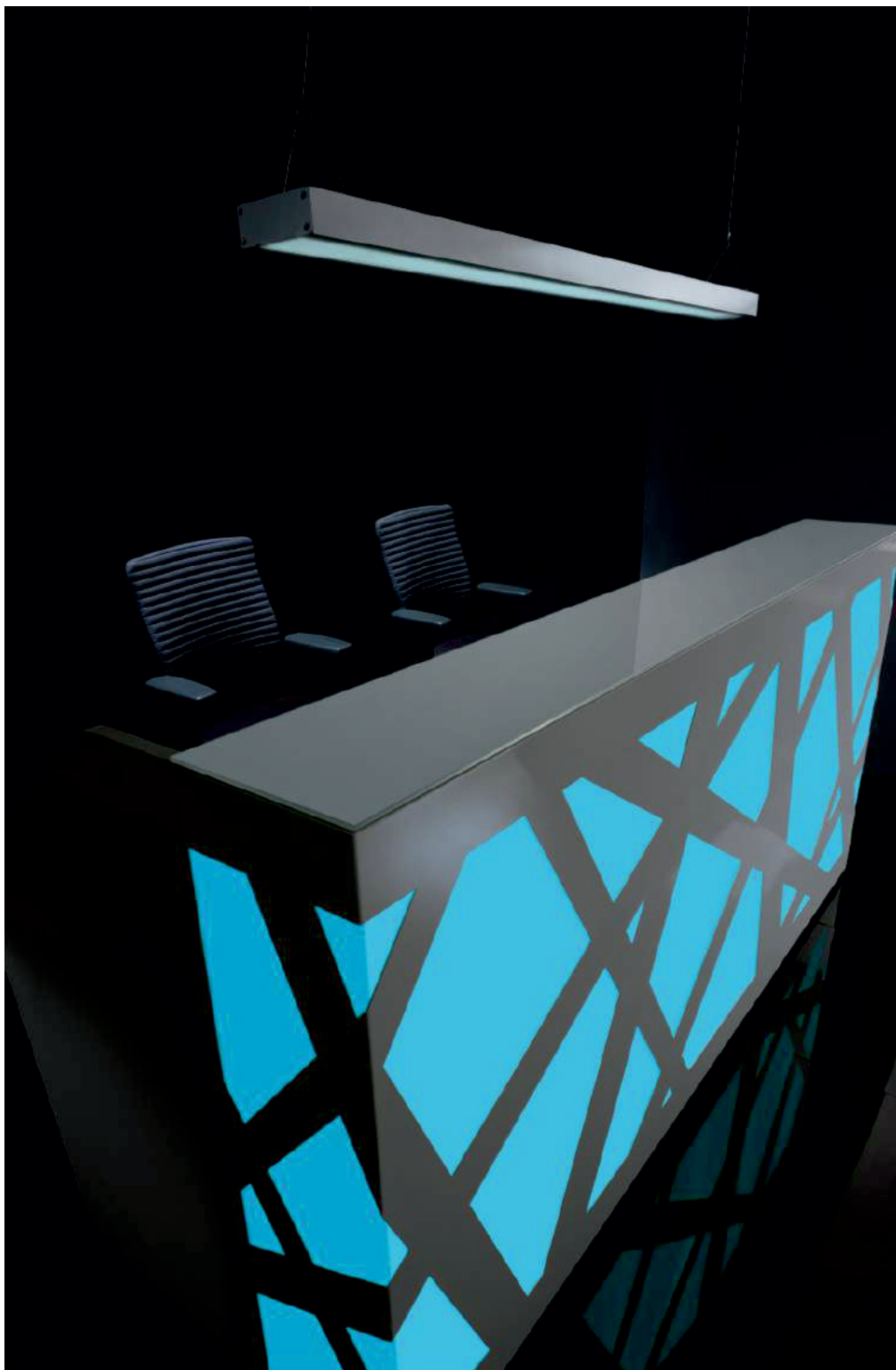



Informations générales :

Garantie :

5 ans.

Composants électriques et tissus - **2 ans.**

Mélangé - certifié :



Densité du panneau :

12 mm - 690 - 750 kg/m³

18 mm - 650 - 690 kg/m³

28 mm - 610 - 630 kg/m³

36 mm - 610 - 630 kg/m³

Montage :

livrée en pièces détachées

Emballage :

Banque de réception placée sur une palette, une pellicule de mousse et 5 couches de carton recouvre l'ensemble.

Le colis est solidarisé avec du ruban polypropylène; carton, enveloppe en plastique perforé, film étirable

Descriptif technique

1. Top - verre trempé optiwhite, 8 mm - laqué du dessous
2. Plan de travail - mélaminé 28 mm, chants ABS
3. Façade - élément en métal finition peinture poudre époxy et plexiglass
4. Éclairage RGBW LED - télécommande
5. Pied bas - mélaminé 28 mm, chants ABS
6. Vérins de réglage - course de 5 mm
7. Obturateurs - Ø80 mm
8. Pied de support NL41 - en métal, nécessaire pour la jonction des plateaux
9. Cloison latérale - mélaminé 28 mm, chants ABS

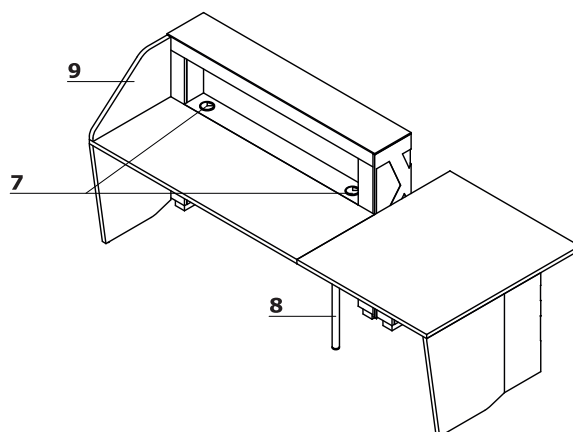
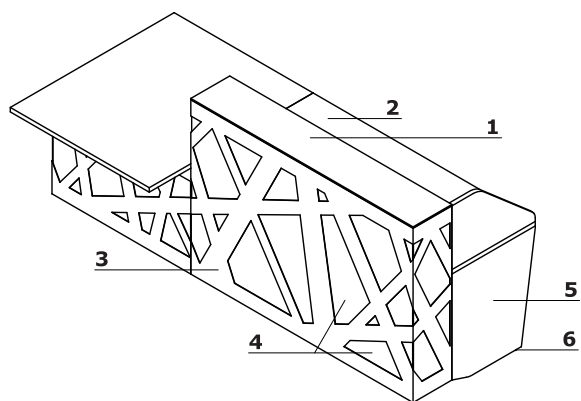

Dimensions

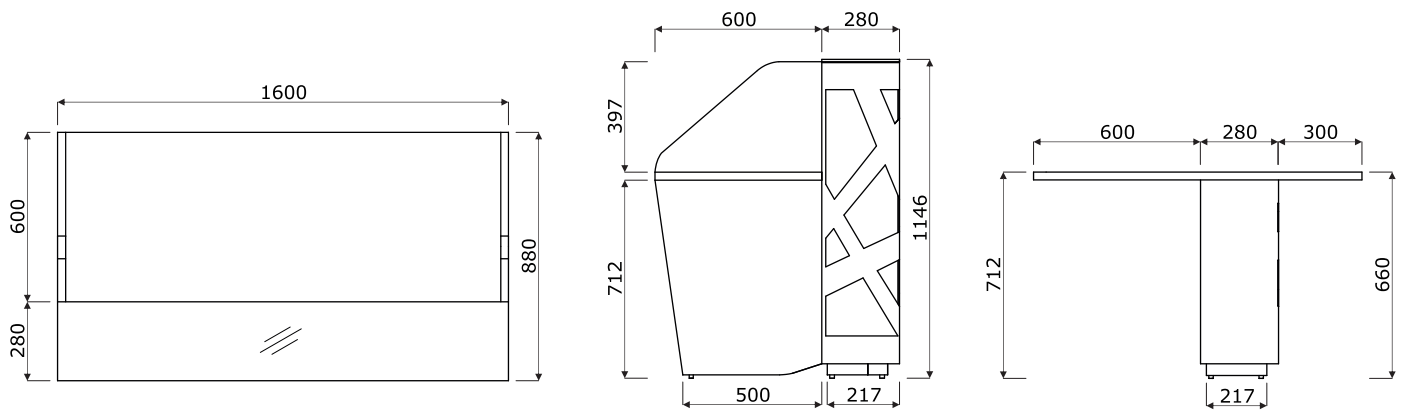

Date
18.12.2019

Ces données sont valides à la date d'élaboration.
Les évolutions des produits, si elles ne touchent pas les caractéristiques fondamentales,
n'impliquent pas une mise à jour systématique de la fiche technique.

page 4/6
dimensions (mm)

Éléments de composition *

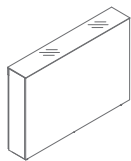

LZG16M
1600 / 280 / 1146
88,5 kg



LZG16
1600 / 280 / 1146
86,5 kg

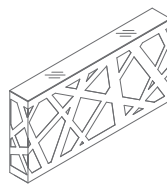

LZG22
2200 / 280 / 1146
107,5 kg

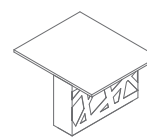

LZG10
1000 / 1180 / 740
80 kg



LZB16M
720 / 600 / 28
10,4 kg

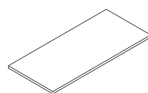

LZB22M
1320 / 600 / 28
18,1 kg

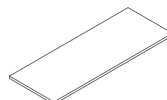

LZB16
1600 / 600 / 28
18,4 kg

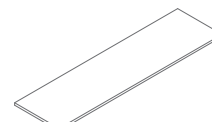

LZB22
2200 / 600 / 28
25,4 kg



LZK01
600 / 28 / 397
7 kg

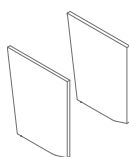

LZN51
600 / 28 / 712
15 kg



NE41L
40 / 40 / 712
1,5 kg



NL41
585 / 142 / 712
2 kg

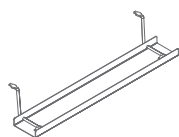

E64L
460 / 89 / 120
0,5 kg

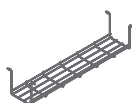

S69L
580 / 162 / 123
1 kg

* Dimensions exprimées en millimètre : Largeur x Profondeur x Hauteur

	Date 18.12.2019	Ces données sont valides à la date d'élaboration. Les évolutions des produits, si elles ne touchent pas les caractéristiques fondamentales, n'impliquent pas une mise à jour systématique de la fiche technique.	page 5/6
			synoptique

Top de rehausse



117 Verre blanc
RAL9003

Corps



67 Blanc pastel

Façade - métal

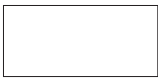

M015 Blanc
semi-mat

Façade - plexiglass



Blanc

Pied de support



M015 Blanc
semi-mat
